

# Dual/Single Output Axle Generator

Q-Tron Part No. Q-93262/1

Product Information Sheet

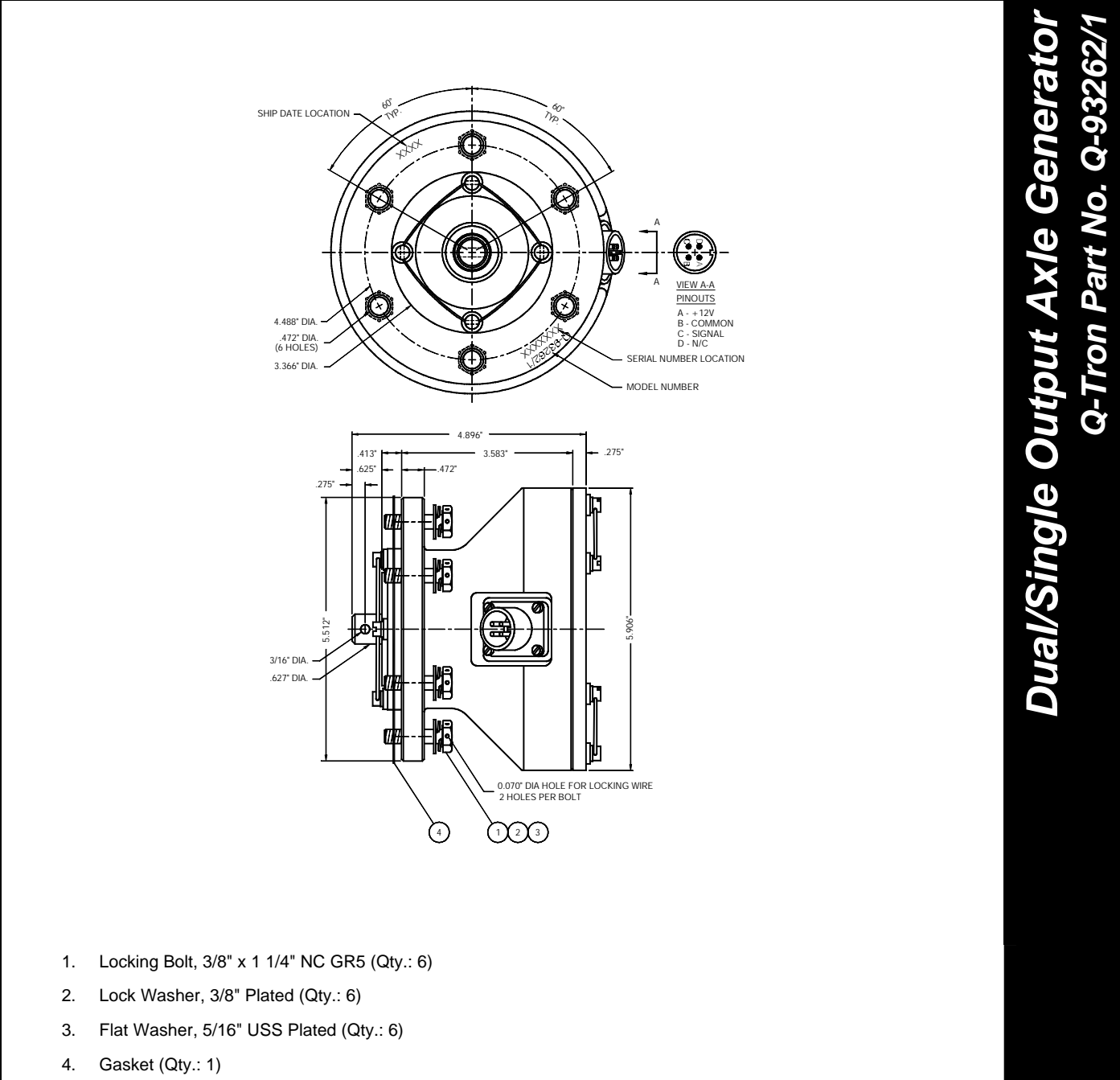

**Dual/Single Output Axle Generator**  
**Q-Tron Part No. Q-93262/1**

Figure 1. Dual/Single Output Axle Generator application



## ***Axle Generator Specifications***

|                        |   |
|------------------------|---|
| Q-Tron Part No.:       | Q-93262/1   |
| Pulses Per Revolution: | 240 PPR   |
| Frequency:             | Speed dependent, 0–2000 Hz maximum (approximately 60 MPH)   |
| Supply Voltage:        | 12–15 VDC at 50 mA  |
| Output Signal:         | 0–10V peak, nominal (maximum is supply voltage dependent), asymmetrical square wave, 50% ± 15% duty cycle |
| Connector              | 4-pin   |

## ***Operations***

Q-Tron's Q-93262/1 Dual Output Axle Generator converts the rotation of the locomotive axle into a pair of 240 PPR electrical signals: Signal A and Signal B. The circuits inside the axle generator deliver two 0–10V square wave signals with a frequency proportional to the rotational speed of the locomotive axle. The phase relationship between the two signals is 90 degrees, with Signal A lagging Signal B when the generator is mounted on the left side of the locomotive and traveling in the forward direction.

Note: When stationary, the output signal may remain in either low (0V) or high (10V) conditions, depending on the position of the axle.

The axle generator operates on a 12–15 VDC supply from an isolated source. This power supply can be provided from a number of Q-Tron products, such as speedometers, event recorders, or one of Q-Tron's Speed Signal Distribution Panels.

A single cable, carrying power and the output signal, is connected to the generator using a Mil. Spec. MS type connector. For applications requiring more than one isolated signal, use axle generators in conjunction with Speed Signal Distribution Panels.

Note: Hermetically sealed, the axle generator does not require any internal maintenance before the recommended five-year rebuild. **DO NOT OPEN THE AXLE GENERATOR**; there are no user serviceable parts in the unit.

### ***Axle Generator Driveshaft Accessories***

Driveshafts provide durable and maintenance-free coupling between the axle generator and the locomotive axle. The shaft material is double-wound, opposing spring steel, designed to resist wear regardless of the axle rotation direction. The spline adapter is molded in place and provides eight bearing surfaces to distribute the rotational force of the axle spline, four surfaces in each direction. Connection hardware (screw, nut, washers) is provided with the driveshaft.

Driveshafts are available in 111, 156, 192, and 236 mm lengths. To determine the driveshaft length for your application, refer to Q-Tron Drawing No. Q-80065-D2-XX, where XX refers to the latest revision (available upon request).

### ***Axle Generator Cables and Cable Mounting Bracket Accessories***

Both the Q-87189C02XXX and the Q-87189C03XXX Axle Generator Cables (where XXX is the cable length in feet) use a black common return for power and signals. The red conductor carries power into the axle generator; the white conductor carries the signal out. Cable Q-87189C02XXX contains a fourth conductor (blue), which carries the second speed signal.

A 1/16" steel aircraft strain relief cable is also molded inside the axle generator cables. The strain relief cable is terminated to the connector housing, preventing strain from affecting the current-carrying conductors.

Axle generator cables are sheathed in a polyurethane jacket with the connector at the axle generator end molded in place to provide added weatherproofing and durability. A custom molded boot covering the connection area offers additional protection against dirt, weather, and damage caused by trackside debris.

For extra security, Q-Tron supplies a heavy steel bracket (Q-Tron Part No. Q-80080) to shroud the connector area, further protecting the connector from mechanical damage.

## ***Mounting Instructions***

The axle generator installation procedure applies to all Q-Tron Axle Generator kits. Each kit includes the required mounting hardware and gasket. For more information about the mounting hardware and gasket, see Figure 3.

**Important:** For applications using early series, pre-1985, EMD Axle Journal Box Adapter, the axle end adapter must have an oil drain hole. If the axle end adapter does not have an oil drain hole, drill one before installation. Refer to the Installation Notice for instructions and further information.

1. Using the connection hardware provided, connect the driveshaft to the axle generator. Use a hammer to start the shoulder screw (and one washer) into the driveshaft. After the shoulder screw is started, align the driveshaft on the axle generator and press the screw all the way in. Add the remaining washer and with 20 in-lb torque, tighten the nut in place to finish the connection.
2. Insert the molded axle generator cable through the cable mounting bracket and strain relief. Leave the strain relief loose to allow the cable to slide through.
3. Connect the axle generator cable connector to the axle generator and ensure the threaded retaining ring is hand-tight.

**Important:** DO NOT TIGHTEN THE THREADED RING USING TOOLS; hand-tightening provides a secure, waterproof seal.

4. Align the dust cover with the ridges on the molded back shell of the connector. Pull the dust cover down until it completely covers the locking ring. The tongue on the dust cover should stick out to allow for easy removal in the future.
5. Mount the cable bracket with the bolts that secure the axle generator, as shown in Figure 3. Orient the bracket 30° from top-vertical, position toward the front of the locomotive.
6. Tighten all axle generator mounting bolts.
7. Tighten the cable strain relief.
8. Install cable supports on the truck at approximately two-foot intervals. Ensure a small loop of cable is left to allow movement of the journal box.

9. Route the cable toward the center of the truck and up through the deck of the locomotive, similar to that of an air brake line. Ensure that sufficient length is left to allow for movement of the truck. Also, ensure that protection is provided at the point where the cable is routed through the deck. Q-Tron recommends using a 3/4" strain relief bushing to provide a good seal and to protect against chaffing where the cable enters the locomotive's sub-floor.

Note: To provide years of trouble-free operation, ensure the molded axle generator cable is correctly routed and adequately clamped.

10. Route the axle generator cable to a spare terminal on a terminal board in the control stand or another suitable location, supporting the cable with wire ties where necessary.

**CAUTION: Switch off the power supply breaker to the axle generator and controlling equipment.**

11. Connect the cable wires to the terminal connectors. Refer to Figure 2 for connection information. For detailed connection information, request the appropriate Q-Tron cable drawing.
12. Before turning on the breaker, check all connections to ensure crimp connections are tight, the shield is properly terminated, and connections are made to the correct terminals.

| Function                        | Cable Q-87189C02XXX |           | Cable Q-87189C03XXX |           |
|---------------------------------|---------------------|-----------|---------------------|-----------|
|                                 | Wire Color          | Connector | Wire Color          | Connector |
| +12 VDC Power to Axle Generator | Red                 | A         | Red                 | A         |
| Power/Signal Return             | Black               | B         | Black               | B         |
| Signal A                        | White               | C         | White               | C         |
| Signal B                        | Blue                | D         | N/A                 | N/A       |
| Shield                          | Bare Wire           | —         | Bare Wire           | —         |

Figure 2. Q-93262/1 Axle Generator Cable Wire Colors and Connectors

- Figure 2 Note:
1. Q-87189C02XXX and Q-87189C03XXX Axle Generator Cables may vary in length and type, depending on the installation (where XXX equals cable length, in feet).
  2. Signal B is not used for Q-87189C03XXX cables.
  3. The strain relief wire does not need to be terminated. Care must be taken to ensure the strain relief wire is not confused with one of the conductors. Though it is jacketed like a conductor, the strain relief wire is heavier and much stiffer.

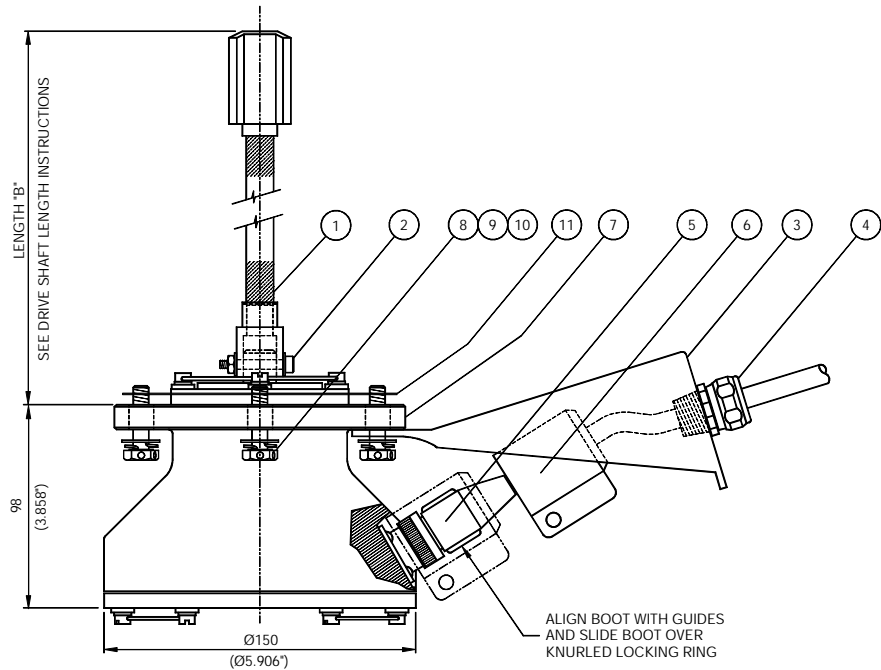

1. Flexible Driveshaft (Qty.: 1)
2. Connection Hardware – supplied with driveshaft (Qty.: 1)
3. Cable Mounting Bracket\* (Qty.: 1)
4. Strain Relief (Qty.: 1)
5. Axle Generator Cable (Qty.: 1)
6. Locking Boot – supplied with cable (Qty.: 1)
7. Axle Generator (Qty.: 1)
8. Locking Bolt, 3/8" x 1 1/4" NC GR5 (Qty.: 6)
9. Lock Washer, 3/8" Plated (Qty.: 6)
10. Flat Washer, 5/16" USS plated (Qty.: 6)
11. Gasket (Qty.: 1)

Figure 3. Axle Generator Accessories and Descriptions

Figure 3 Note: \* Item 3, Mounting Bracket varies depending on the installation. Newer General Motors (EMD) installations may use Q-Tron Part No. Q-80080/7 bracket, which includes a hose nipple that replaces the strain relief. Only this bracket includes a hose nipple, all other mounting bracket applications are installed as instructed in this document.

## Installation Notice

All early series, pre-1985, EMD Axle Journal Box Adapters must have an oil drain hole. This drain hole is necessary to drain oil, which can be forced into the unit, from the axle generator.

If the axle end adapter does not have an oil drain hole, it must be drilled before installing the axle generator. See Figure 4 for hole drilling location. Use a drilling jig (Q-Tron Part No. Q-85139, see Figure 5) when drilling the drain hole to ensure correct placement.

Note: EMD Axle Journal Box Adapters manufactured since 1985 have the necessary oil drain hole. Users are not required to drill one prior to axle generator installation.

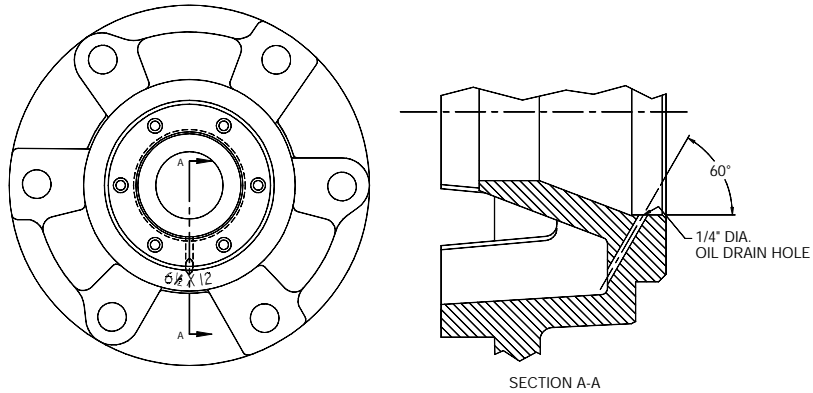

Figure 4. Oil Drain Hole Location

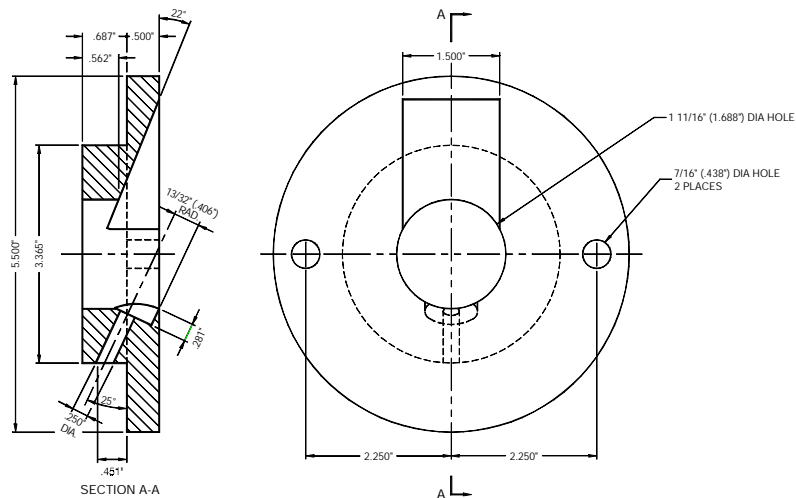

Figure 5. Oil Drain Hole Drilling Jig