

Axle Generator Junction Box, Positions 7-12

Q-Tron Part No. 7216.1202
Product Information Sheet

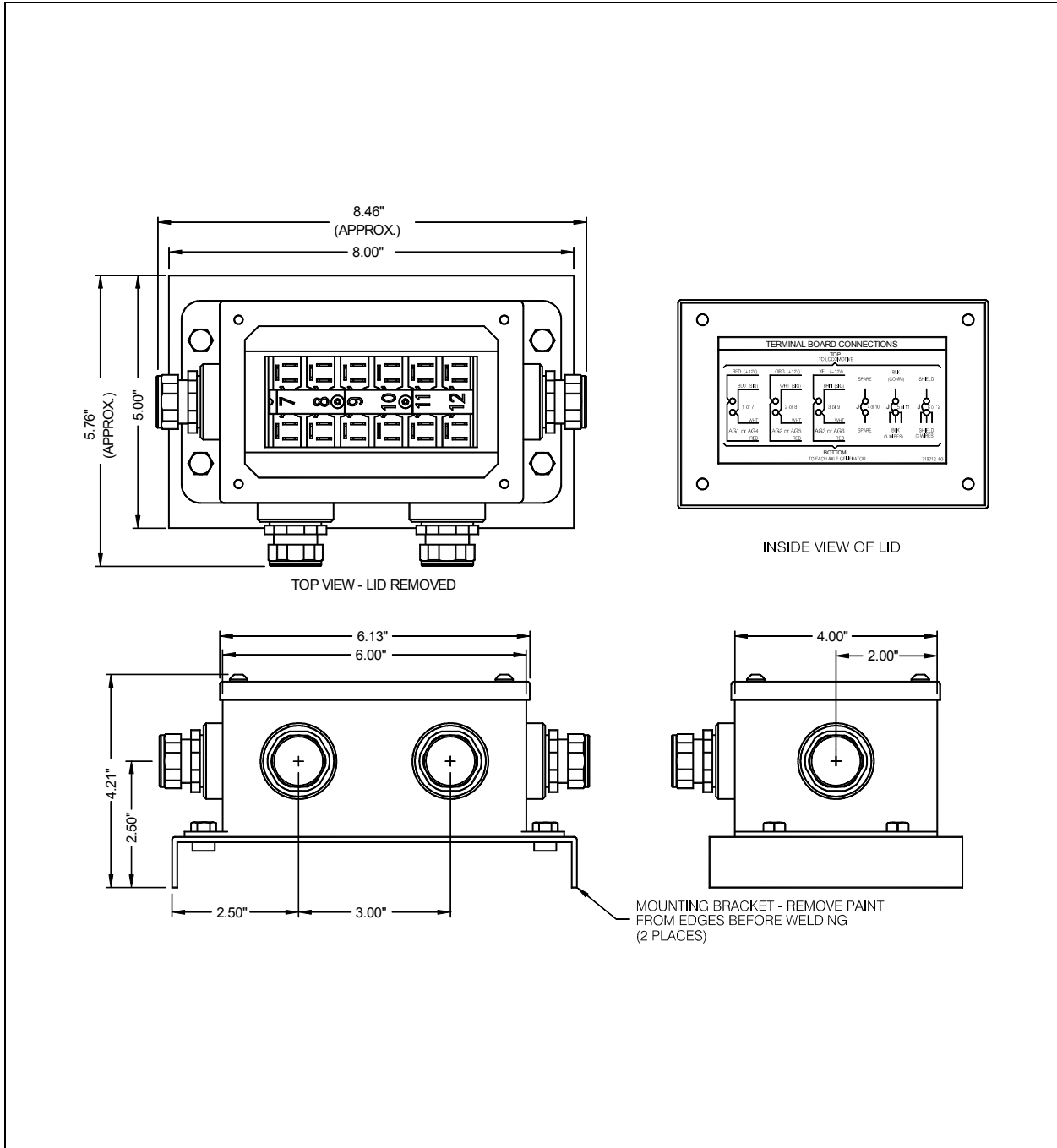

Axle Generator Junction Box, Positions 7-12
Q-Tron Part No. 7216.1202

Figure 1. Axle Generator Junction Box, Positions 7-12 application



Axle Generator Junction Box, Positions 7–12 Specifications

Q-Tron Part No.:	7216.1202
Weight:	3 lb (1.5 kg)
Connections:	See Figure 1 for connection information.

Operations

The Axle Generator Junction Box is an electrical junction box for Q-Tron systems requiring more than one axle generator (QES 1000, QES-III, and QTRAC 1000). Mounted to the car body, the junction box provides termination from the axle generator cables. It also provides termination for the cable connected from the junction box to the main electrical cabinet of the locomotive.

Mounting Instructions

Mount the Axle Generator Junction Box in a suitable location above the truck. Remove the paint from the bottom edges of the mounting bracket (see Figure 1) before welding the junction box in place.