

Inductor Assembly

Q-Tron Part No. 7216.0901

Product Information Sheet

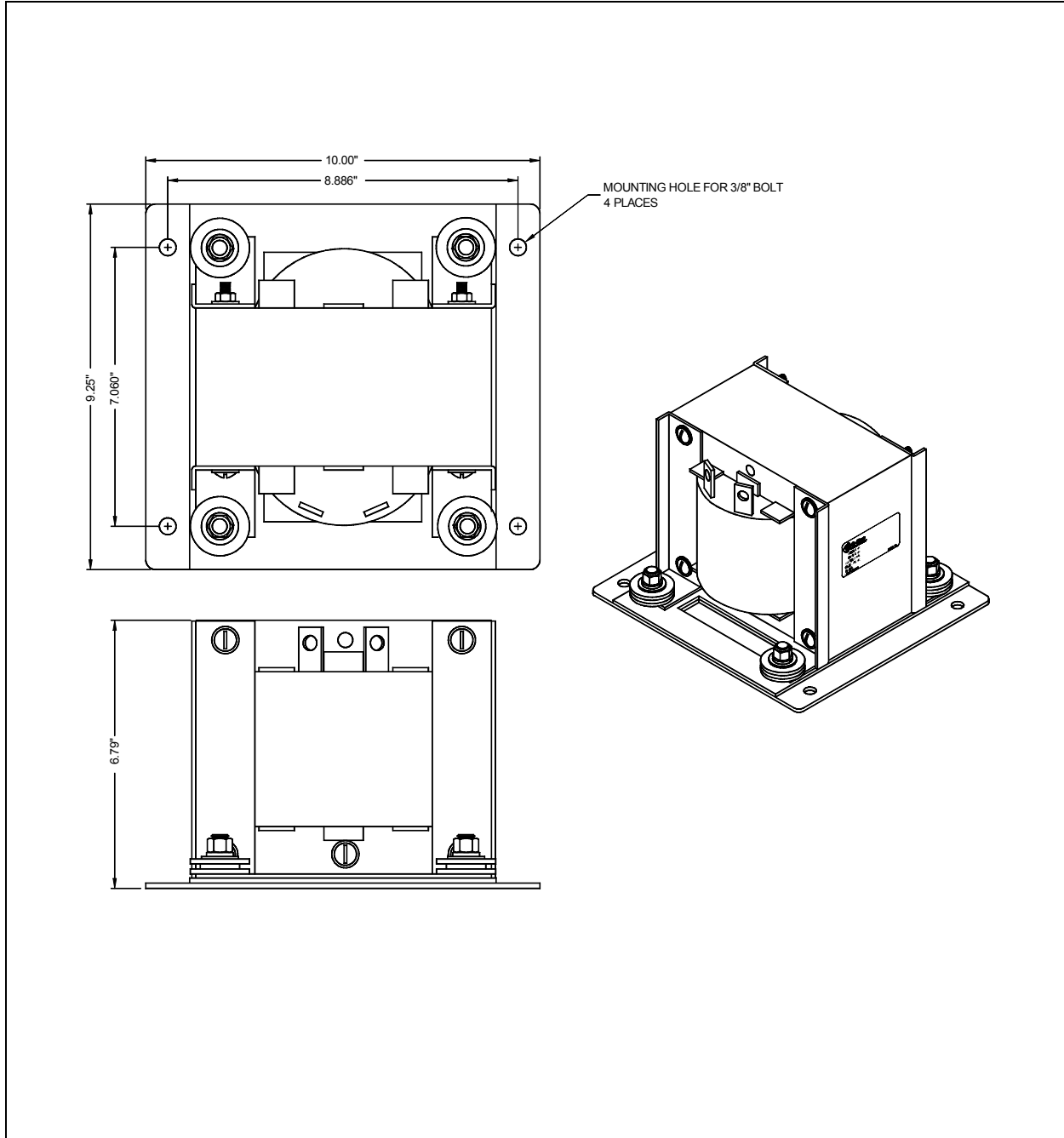

Inductor Assembly
Q-Tron Part No. 7216.0901

Figure 1. Inductor Assembly application



Inductor Assembly Specifications

Q-Tron Part No.:	7216.0901
Weight:	Approximately 60 lb (27.6 kg)

Operations

Q-Tron's Inductor Assembly protects the traction motor system against voltage irregularities originating from the main generator. The main generator produces a ± 200 VAC ripple (at 225 Hz), which, if not effectively filtered, can lead to traction motor system damage.

Mounting Instructions

Install the Inductor Assembly in a suitable location in the main electrical cabinet.